

UTP Cat.5 8P8C plug assembly instruction

1. Strip the cable jacket about 40 mm to expose wires.



2. Separate and sort the wires according to specified color codes.



3. Cut the sorted wires at an approximately 30 degree angle to make insertion easier.



4. Fit the wires into the plug insert.

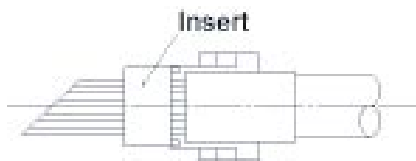

5. Cut off the excess wires that extend from the plug insert.

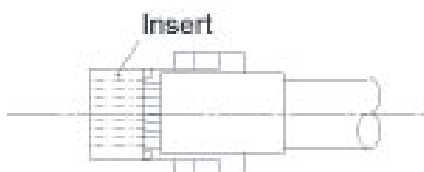

6. Place the insert into the housing. Make sure the plug insert fits tightly in the housing.

Also check that the back of the insert is completely enclosed within the housing.

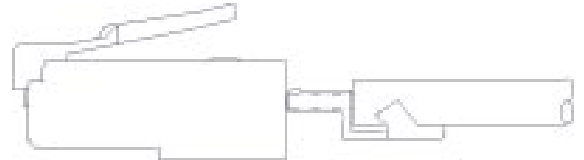

7. Use crimping machine (P/N HT8001) to crimp the plug contact blades.

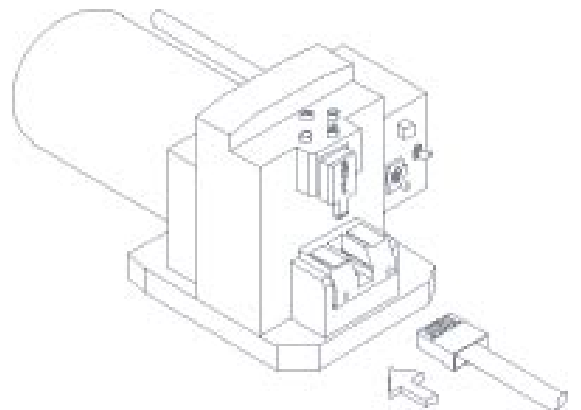

8. or use crimping tool to crimp the plug contact blades.

