

TIA568-B.2 Channel

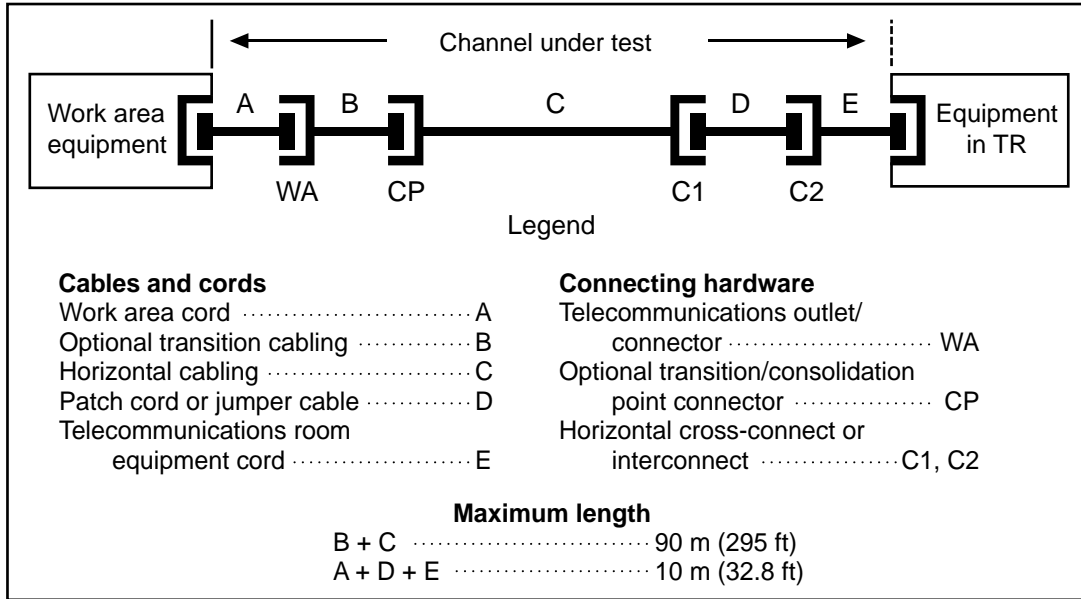

Permanent link

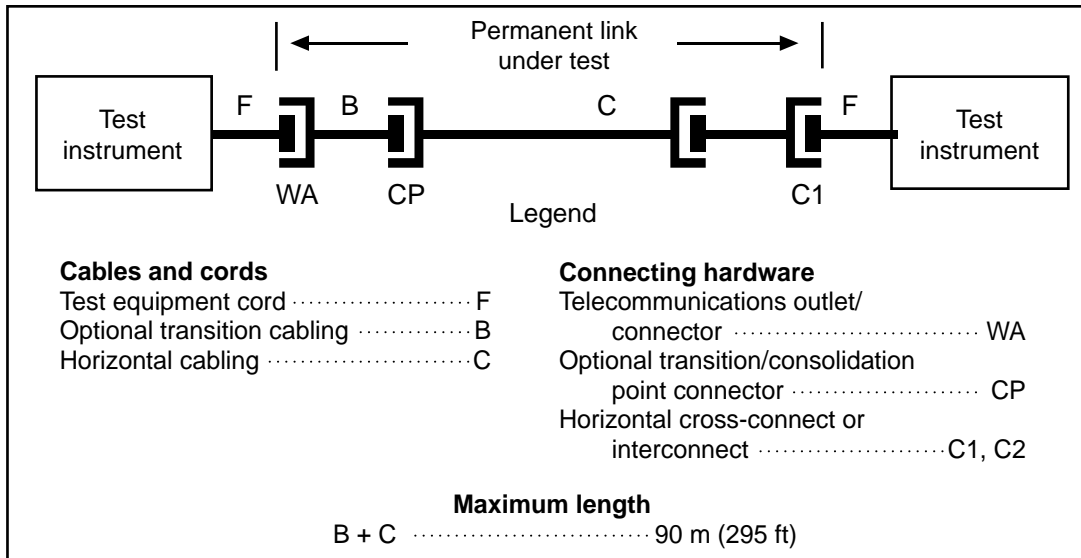

ISO/IEC 11801

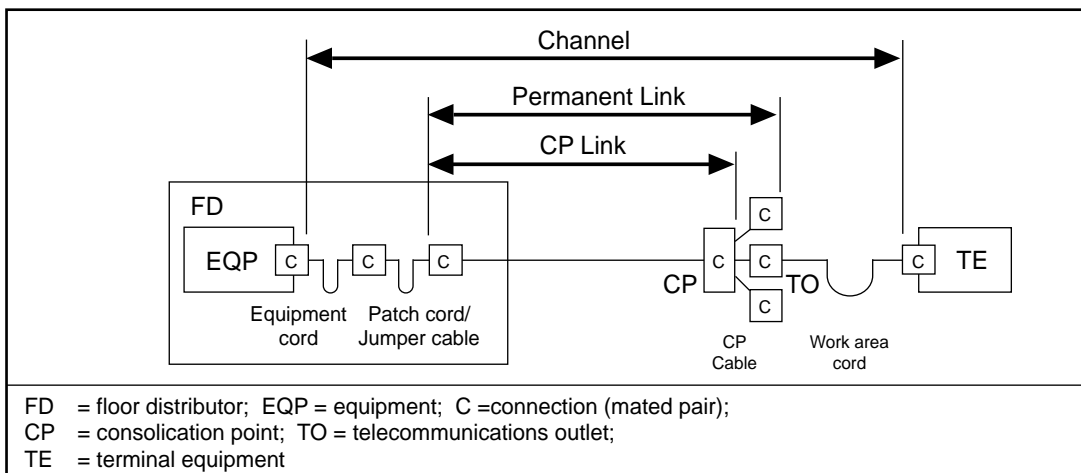

Figure 9 - Channel, permanent link and CP link of a balanced cabling

Table 51 - Return loss

Electrical characteristics	Frequency MHz	Requirement			Test standard
		Connector category			
		5	6	7	
Minimum return loss ^a dB	1-100	$60 - 20\log(f)$	-	-	IEC 60512-25-5 (draft)
	1-250	-	$64 - 20\log(f)$	-	
	1-600	-	-	$68 - 20\log(f)$	
Minimum return loss at key frequencies dB	1	30,0	30,0	30,0	
	100	20,0	24,0	28,0	
	250	-	16,0	20,0	
	600	-	-	12,4	

^a Return loss at frequencies that correspond to calculated values of greater than 30,0 dB shall revert to a minimum requirement of 30,0 dB.

Table 52 - Insertion loss

Electrical characteristics	Frequency MHz	Requirement			Test standard
		Connector category			
		5	6	7	
Maximum insertion loss ^a dB	1-100	$0,04\sqrt{f}$	-	-	IEC 60512-25-2 (draft)
	1-250	-	$0,02\sqrt{f}$	-	
	1-600	-	-	$0,02\sqrt{f}$	
Maximum insertion loss at key frequencies dB	1	0,10	0,10	0,10	
	100	0,40	0,20	0,20	
	250	-	0,32	0,32	
	600	-	-	0,49	

^a Insertion loss at frequencies that correspond to calculated values of less than 0,1 dB shall revert to a requirement of 0,1 dB maximum.

Table 53 - Near end crosstalk (NEXT)

Electrical characteristics	Frequency MHz	Requirement			Test standard
		Connector category			
		5	6	7	
Minimum near end crosstalk (NEXT) ^a dB	1-100	$83 - 20\log(f)$	-	-	IEC 60512-25-1 (draft)
	1-250	-	$94 - 20\log(f)$	-	
	1-600	-	-	$102,4 - 19\log(f)$	
Minimum NEXT at key frequencies dB	1	80,0	80,0	80,0	
	100	43,0	54,0	72,4	
	250	-	46,0	66,4	
	600	-	-	60,7	

^a NEXT at frequencies that correspond to calculated values of greater than 80,0 dB shall revert to a minimum requirement of 80,0 dB.

Table 54 - Power sum near end crosstalk (PS NEXT)
Information only

Electrical characteristics	Frequency MHz	Requirement ^b			Test standard
		Connector category			
		5	6	7	
Minimum power sum near end crosstalk (PS NEXT) ^a dB	1-100	80 - 20log(f)	-	-	IEC 60512-25-1 (draft)
	1-250	-	90 - 20log(f)	-	
	1-600	-	-	99,4 - 15log(f)	
Minimum PS NEXT at key frequencies dB	1	77,0	77,0	77,0	
	100	40,0	50,0	69,4	
	250	-	42,0	63,4	
	600	-	-	57,7	

^a PS NEXT at frequencies that correspond to calculated values of greater than 77,0 dB shall revert to a minimum requirement of 77,0 dB.

^b Equations and values for power sum NEXT are provided for information only.

Table 55 - Far end crosstalk (FEXT)

Electrical characteristics	Frequency MHz	Requirement			Test standard
		Connector category			
		5	6	7	
Minimum far end crosstalk (FEXT) ^{a, b} dB	1-100	75,1 - 20log(f)	-	-	IEC 60512-25-1 (draft)
	1-250	-	83,1 - 20log(f)	-	
	1-600	-	-	90 - 15log(f)	
Minimum FEXT at key frequencies dB	1	65,0	65,0	65,0	
	100	35,1	43,1	60,0	
	250	-	35,1	54,0	
	600	-	-	48,3	

^a FEXT at frequencies that correspond to calculated values of greater than 65,0 dB shall revert to a minimum requirement of 65,0 dB.

^b For connectors, the difference between FEXT and ELFEXT is minimal. Therefore, connector FEXT requirements are used to model ELFEXT performance for links and channels.

Table 56 - Power sum far end crosstalk (PS FEXT)
Information only

Electrical characteristics	Frequency MHz	Requirement ^c			Test standard
		Connector category			
		5	6	7	
Minimum power sum far end crosstalk (PS FEXT) ^{a, b} dB	1-100	72,1 - 20log(f)	-	-	IEC 60512-25-1 (draft)
	1-250	-	80,1 - 20log(f)	-	
	1-600	-	-	87 - 15log(f)	
Minimum PS FEXT at key frequencies dB	1	62,0	62,0	62,0	
	100	32,1	40,1	57,0	
	250	-	32,1	51,0	
	600	-	-	45,3	

^a PS FEXT at frequencies that correspond to calculated values of greater than 62,0 dB shall revert to a minimum requirement of 62,0 dB.

^b For connectors, the difference between PS FEXT and PS ELFEXT is minimal. Therefore, connector PS FEXT requirements are used to model PS ELFEXT performance for links and channels.

^c Equations and values for power sum FEXT are provided for information only.

Table 57 - Input to output resistance

Electrical characteristics	Frequency	Requirement			Test standard
		Connector category			
		5	6	7	
Maximum input to output resistance ^a mΩ	d.c.	200	200	200	IEC 60512-2 Test 2a

^a Input to output resistance is a separate measurement from the contact resistance measurements required in IEC 60603-7. Input to output resistance is measured from cable termination to cable termination to determine the connector's ability to transmit direct current and low frequency signals. Contact resistance measurements are used to determine mechanical and environmental performance of individual electrical connections. These requirements are applicable to each conductor and to the screen, when present.

Table 58 - Input to output resistance unbalance

Electrical characteristics	Frequency	Requirement			Test standard
		Connector category			
		5	6	7	
Maximum input to output ^a resistance unbalance mΩ	d.c.	50	50	50	IEC 60512-2 Test 2a

^a Input to output resistance measurements are made from cable termination to cable termination.

Table 59 - Current carrying capacity

Electrical characteristics	Frequency	Requirement			Test standard
		Connector category			
		5	6	7	
Minimum current carrying capacity ^{a, b, c} A	d.c.	0,75	0,75	0,75	IEC 60512-3 Test 5b

^a Applicable for an ambient temperature of 60 °C.

^b Sample preparation shall be as specified in IEC 60603-7.

^c Applicable to each conductor including the screen, if present.

Table 63 - Transfer impedance Screened connectors only

Electrical characteristics	Frequency MHz	Requirement			Test standard
		Connector category			
		5	6	7	
Maximum transfer impedance Ω	1-10	$0,1f^{0,3}$	$0,1f^{0,3}$	$0,05f^{0,3}$	IEC 60512-25-5 (draft)
	10-80	0,02f	0,02f	0,01f	
Maximum transfer impedance at key frequencies Ω	1	0,10	0,10	0,05	
	10,0	0,20	0,20	0,10	
	80,0	1,60	1,60	0,80	

Table 64 - Insulation resistance

Electrical characteristics	Frequency	Requirement			Test standard
		Connector category			
		5	6	7	
Minimum insulation resistance M Ω	d.c.	100	100	100	IEC 60512-2 Test 3a, Method C @ 500 V d.c.

Table 65 - Dielectric strength

Minimum Dielectric strength V	Frequency	Requirement			Test standard
		Connector category			
		5	6	7	
Conductor to conductor	d.c.	1 000	1 000	1 000	IEC 60512-2 Test 4a
Conductor to test panel	d.c.	1 500	1 500	1 500	

Cat.6 test plug

Table E.2 – Category 6 de-embedded test plug NEXT loss limits

Case #	Pair combination	Limit	NEXT loss magnitude limit ^{1),4),5)}	NEXT loss phase limit ^{2),3)}
Case 1	3,6-4,5	Low	$\leq 36.4-20\log(f/100)$	$(-90 + 1.5 f/100) \pm f/100$
Case 2	3,6-4,5	Central	$(37.0 \pm 0.2)-20\log(f/100)$	$(-90 + 1.5 f/100) \pm f/100$
Case 3	3,6-4,5	High	$\geq 37.6-20\log(f/100)$	$(-90 + 1.5 f/100) \pm f/100$
Case 4	1,2-3,6	Low	$\leq 46.5-20\log(f/100)$	$(-90 + 1.5 f/100) \pm 3 f/100$
Case 5	1,2-3,6	High	$\geq 49.5-20\log(f/100)$	$(-90 + 1.5 f/100) \pm 3 f/100$
Case 6	3,6-7,8	Low	$\leq 46.5-20\log(f/100)$	$(-90 + 1.5 f/100) \pm 3 f/100$
Case 7	3,6-7,8	High	$\geq 49.5-20\log(f/100)$	$(-90 + 1.5 f/100) \pm 3 f/100$
Case 8	1,2-4,5	Low	$\leq 57-20\log(f/100)$	$90 \pm (30 f/100)$
Case 9	1,2-4,5	High	$\geq 70-20\log(f/100)$	any phase
Case 10	4,5-7,8	Low	$\leq 57-20\log(f/100)$	$90 \pm (30 f/100)$
Case 11	4,5-7,8	High	$\geq 70-20\log(f/100)$	any phase
Case 12	1,2-7,8	Low	$\leq 60-20\log(f/100)$	any phase

1) Magnitude limits apply over the frequency range from 10 to 250 MHz.
 2) Phase limits apply over the frequency range from 50 to 250 MHz.
 3) When the measured plug NEXT loss is greater than 70 dB, the phase limit does not apply.
 4) When a low limit NEXT loss calculation results in values greater than 70 dB, there shall be no low limit for NEXT loss.
 5) When a high limit NEXT loss calculation results in values greater than 70 dB, the high limit NEXT loss shall revert to a limit of 70 dB.

Table E.4 – Category 6 test plug FEXT loss ranges

Pair combination	Frequency range (MHz)	FEXT loss ^{3),4)} magnitude range (dB)	Phase ^{1),2)} (degrees)
3,6-4,5	10-250	$46-20\log(f/100) \leq \text{FEXT loss} \leq 56-20\log(f/100)$	$-90 \pm (30 f/100)$
1,2-3,6	10-250	$46-20\log(f/100) \leq \text{FEXT loss} \leq 56-20\log(f/100)$	$-90 \pm (30 f/100)$
3,6-7,8	10-250	$46-20\log(f/100) \leq \text{FEXT loss} \leq 56-20\log(f/100)$	$-90 \pm (30 f/100)$
1,2-4,5	10-250	$\geq 55-20\log(f/100)$	any phase
4,5-7,8	10-250	$\geq 55-20\log(f/100)$	any phase
1,2-7,8	10-250	$\geq 55-20\log(f/100)$	any phase

1) When the measured plug FEXT loss is greater than 70 dB, the phase requirement does not apply.
 2) Due to measurement accuracy considerations, phase measurement requirements below 50 MHz are specified for information only.
 3) When upper limit FEXT loss calculations result in values greater than 70 dB, there shall be no upper limit for FEXT loss.
 4) When lower limit FEXT loss calculations result in values greater than 70 dB, the lower limit FEXT shall revert to a limit of 70 dB.

Cat.6 test plug

Table E.1 – Category 6 de-embedded real and imaginary reference jack vectors

Pair	Re_J – Real coefficient of reference jack vector, (V/V) (f = frequency in MHz)
3,6 – 4,5	$= 5.87 \cdot 10^{-11} \cdot f^3 + 2.02 \cdot 10^{-8} \cdot f^2 - 1.10 \cdot 10^{-6} \cdot f$
1,2 – 3,6	$= -1.72 \cdot 10^{-11} \cdot f^3 + 3.81 \cdot 10^{-8} \cdot f^2 - 3.89 \cdot 10^{-7} \cdot f$
3,6 – 7,8	$= 1.28 \cdot 10^{-13} \cdot f^4 - 2.63 \cdot 10^{-11} \cdot f^3 + 5.63 \cdot 10^{-8} \cdot f^2 - 3.62 \cdot 10^{-7} \cdot f$
1,2 – 4,5	$= 8.73 \cdot 10^{-8} \cdot f^2 + 3.07 \cdot 10^{-7} \cdot f$
4,5 – 7,8	$= 2.03 \cdot 10^{-11} \cdot f^3 + 5.08 \cdot 10^{-8} \cdot f^2 + 3.25 \cdot 10^{-7} \cdot f$
1,2 – 7,8	$= -2.51 \cdot 10^{-11} \cdot f^3 + 2.34 \cdot 10^{-8} \cdot f^2 - 2.23 \cdot 10^{-7} \cdot f$
Im_J – Imaginary coefficient of reference jack vector, (V/V) (f = frequency in MHz)	
3,6 – 4,5	$= 3.09 \cdot 10^{-11} \cdot f^3 + 1.77 \cdot 10^{-8} \cdot f^2 - 1.47 \cdot 10^{-6} \cdot f$
1,2 – 3,6	$= -1.09 \cdot 10^{-8} \cdot f^2 + 5.08 \cdot 10^{-6} \cdot f$
3,6 – 7,8	$= -1.86 \cdot 10^{-13} \cdot f^4 + 9.18 \cdot 10^{-11} \cdot f^3 - 9.32 \cdot 10^{-9} \cdot f^2 + 2.74 \cdot 10^{-5} \cdot f$
1,2 – 4,5	$= -2.68 \cdot 10^{-11} \cdot f^3 - 1.20 \cdot 10^{-8} \cdot f^2 + 6.82 \cdot 10^{-5} \cdot f$
4,5 – 7,8	$= -1.67 \cdot 10^{-13} \cdot f^4 + 8.58 \cdot 10^{-11} \cdot f^3 - 2.25 \cdot 10^{-8} \cdot f^2 + 4.96 \cdot 10^{-5} \cdot f$
1,2 – 7,8	$= 6.01 \cdot 10^{-14} \cdot f^4 - 4.58 \cdot 10^{-11} \cdot f^3 + 3.32 \cdot 10^{-10} \cdot f^2 + 9.12 \cdot 10^{-6} \cdot f$

NOTES

- 1 The reference jack vector coefficients in table E-1 were derived from average measurements collected using a 4-balun test fixture set-up with common mode terminations applied to all near-end pairs only.
- 2 The use of a reference jack as specified will improve measurement consistency when using the same reference jack design. Refer to annex H for information on verification of the reference jack design and the consistency of the jack vectors.

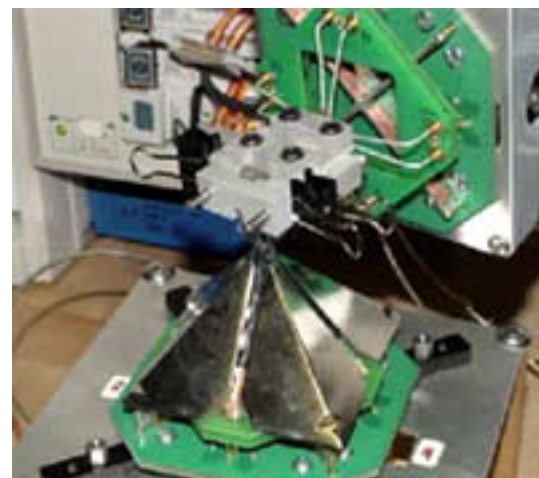

T568-B.2 three levels of Cat.6

Cat.6 channel NEXT loss, worst pair-to-pair

Frequency (MHz)	NEXT loss (dB)
1.0	65.0
4.0	63.0
8.0	58.2
10.0	56.6
16.0	53.2
20.0	51.6
25.0	50.0
31.25	48.4
62.5	43.4
100.0	39.9
200.0	34.8
250.0	33.1

Cat.6 permanent link NEXT loss, worst pair-to-pair

Frequency (MHz)	NEXT loss (dB)
1.0	65.0
4.0	64.1
8.0	59.4
10.0	57.8
16.0	54.6
20.0	53.1
25.0	51.5
31.25	50.0
62.5	45.1
100.0	41.8
200.0	36.9
250.0	35.3

Cat.6 connecting hardware NEXT loss, worst pair-to-pair

Frequency (MHz)	NEXT loss (dB)
1.0	75.0
4.0	75.0
8.0	75.0
10.0	74.0
16.0	69.9
20.0	68.0
25.0	68.0
31.25	64.1
62.5	58.1
100.0	54.0
200.0	48.0
250.0	46.0

Cable and patch cord

Cat.6 cable NEXT loss @ 20°C + 3°C(68°F + 5.5°F), worst pair-to-pair

Frequency (MHz)	NEXT loss (dB)
0.150	86.7
0.772	76.0
1.0	74.3
4.0	65.3
8.0	60.8
10.0	59.3
16.0	56.2
20.0	54.8
25.0	53.3
31.25	51.9
62.5	47.4
100.0	44.3
200.0	39.8
250.0	38.3

Table 8 - Example cat.6 modular plug cord NEXT loss, dB

Frequency (MHz)	2 m cord link (dB)	5 m cord link (dB)	10 m cord link (dB)
1	65.0	65.0	65.0
4	65.0	65.0	65.0
8	65.0	65.0	64.8
10	65.0	64.5	32.9
16	62.0	60.5	59.0
20	60.1	58.6	57.2
25	58.1	56.8	55.4
31.25	56.2	54.9	53.6
62.5	50.4	49.2	48.1
100	46.4	45.3	44.4
125	44.5	43.5	42.7
150	43.0	42.1	41.4
175	41.8	40.9	40.2
200	40.6	39.8	39.3
225	39.7	38.9	38.4
250	38.8	38.1	37.6

Table K.3 - Example cat.6 modular plug cord NEXT loss, dB

[dB par 100m(328ft) @ 20°C]

Frequency (MHz)	Cat.3		Cat.5e	
	26AWG	24AWG	26AWG	24AWG
0.772	3.3	2.7	2.7	2.2
1	3.8	3.1	3.0	2.4
1	8.1	6.7	6.2	1.9
8	12.7	10.2	8.7	6.9
10	14.6	11.7	9.8	7.8
16	19.6	15.7	12.3	9.9
20	-	-	14.0	11.1
25	-	-	15.7	12.5
31.25	-	-	17.7	14.1
62.5	-	-	25.6	20.5
100	-	-	33.0	26.5

Transfer impedance in STP system

Table K.1-Maximum cable surface transfer impedance

Frequency (MHz)	Cat.3 mΩ/m	Cat.5e mΩ/m
1	50	50
10	100	100
16	130	130
20	-	148
100	-	500

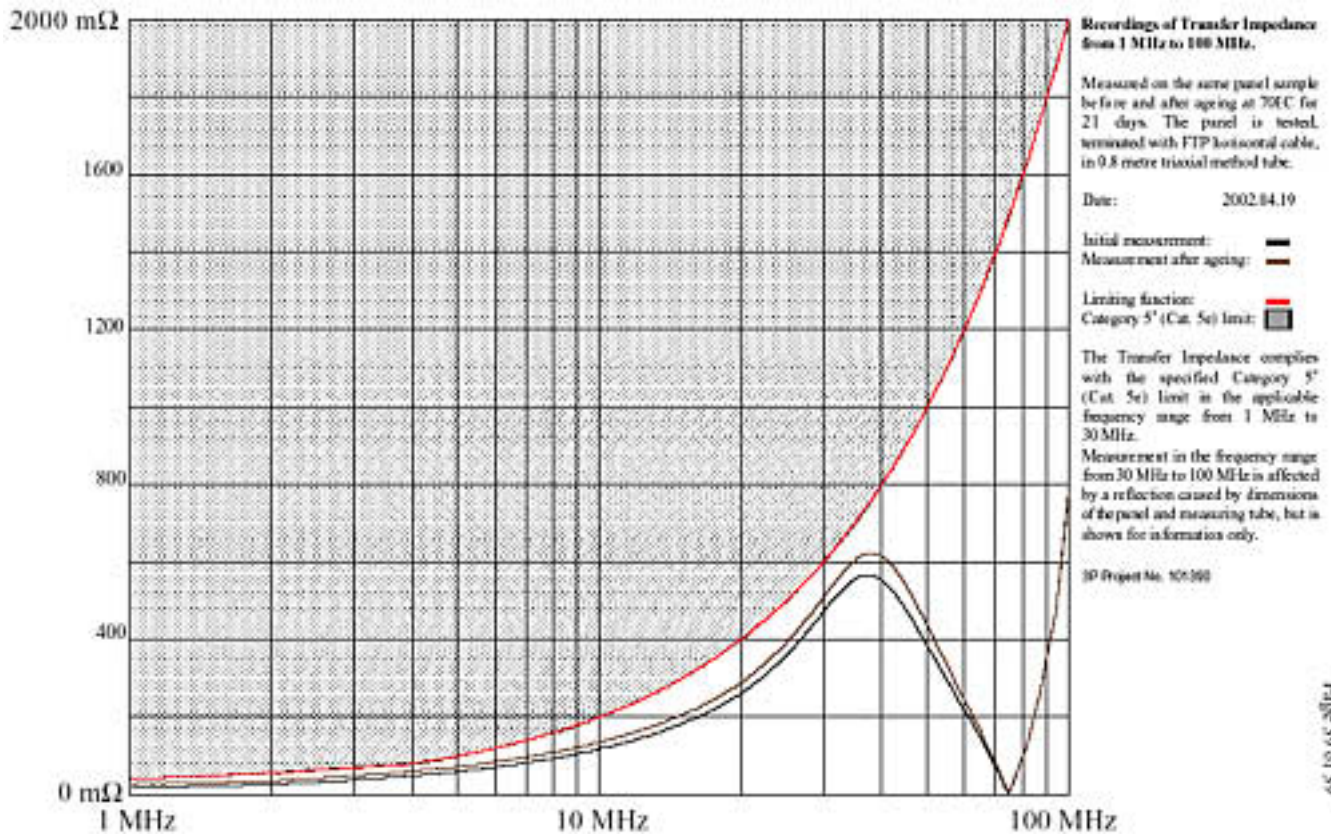

T568-B.2 Annex K Shield interface

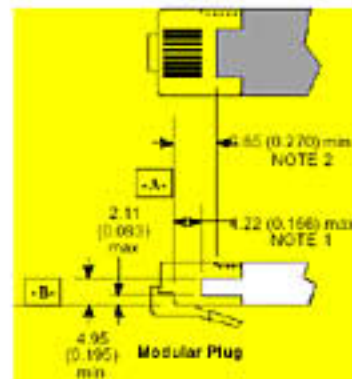
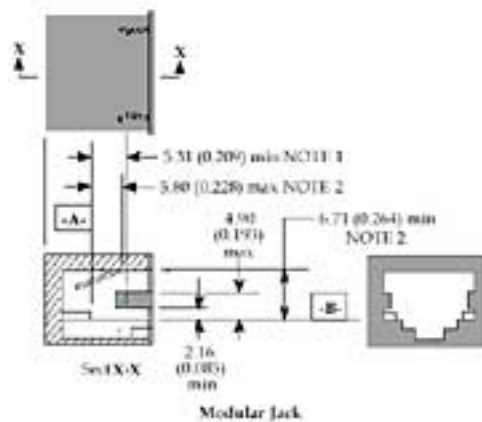

1- Shield interface requirements for 8-position modular connectors

IEC60603-7

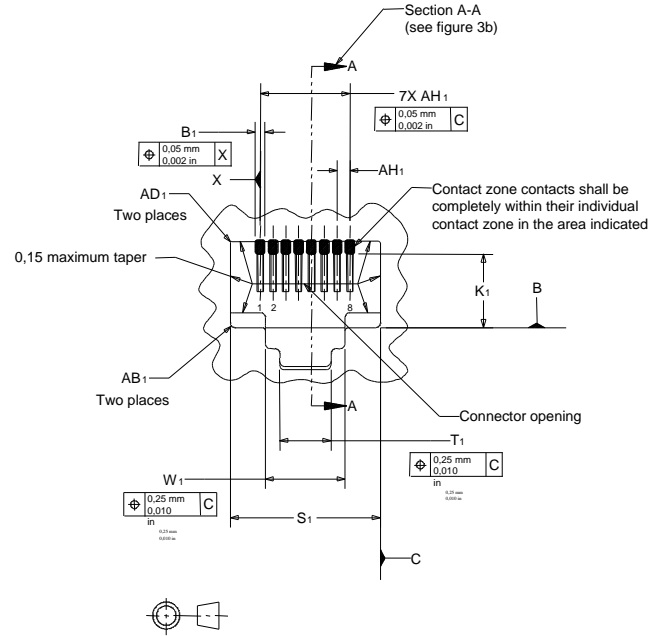
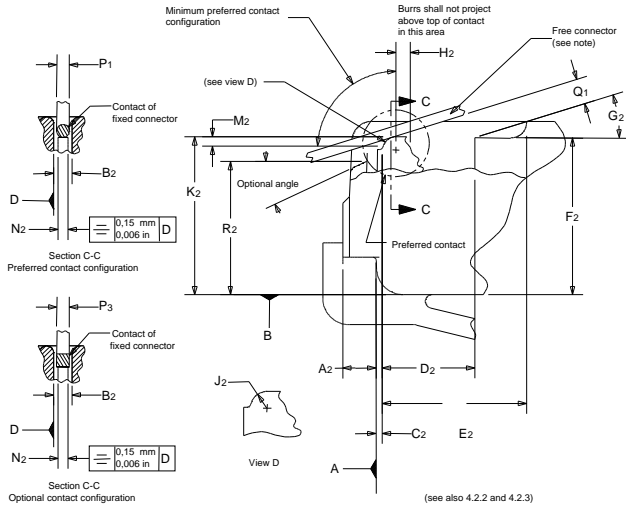

NOTE - The mating information shown can only be achieved with a free connector with cable attached.

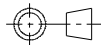
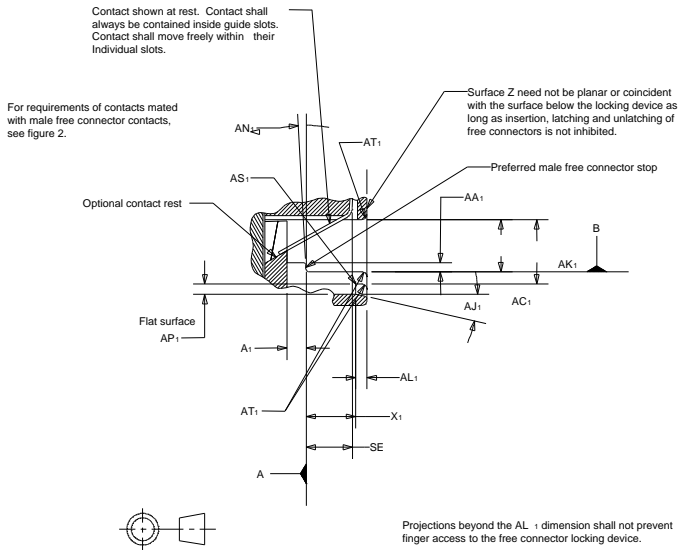

Projections beyond the AL₁ dimension shall not prevent finger access to the free connector locking device.

IEC60603-7

Mechanical characteristics		Requirement	Component or test standard	
a)	Physical dimensions (only at telecommunications outlet)	Category 5 unshielded	Mating dimensions and gauging	IEC 60603-7-2
		Category 5 shielded	Mating dimensions and gauging	IEC 60603-7-3
		Category 6 unshielded	Mating dimensions and gauging	IEC 60603-7-4
		Category 6 shielded	Mating dimensions and gauging	IEC 60603-7-5
		Category 7	Mating dimensions and gauging	IEC 60603-7-7 ¹
b)	Cable termination compatibility			
	Nominal conductor diameter - mm	0,5 to 0,65 ^a	-	
Cable type	Patching ^d	Stranded conductors	-	
	Jumpers	Stranded or solid conductors	-	
	Other	Solid conductors	-	
Nominal diameter of insulated conductor mm	Categories 5 and 6	0,7 to 1,4 ^{b, c}	-	
	Category 7	0,7 to 1,6		
Number of conductors	Telecommunications outlet	8	Visual Inspection	
	Other	≥ 2 ⁿ (n = 1,2,3, ...)		
Cable outer diameter mm	Outlet	≤ 20	-	
	Plug	≤ 9 ^a		
	Means to connect screen ^f	-	Annex C and clause 11	
c)	Mechanical operation (durability)			
Cable termination (cycles)	Non-reusable IDC	1	IEC 60352-4	
	Reusable IDC	≥ 20	IEC 60352-3	
	Non-reusable IPC (plug)	1	IEC 60352-6	
Jumper termination (cycles)		≥ 200 ^g	IEC 60352-3	
TO-type interface (cycles)		≥ 750 ^h	IEC 60603-7, level P1	
Other connections		≥ 200 ^h	Annex C	

Table 50 - Electrical characteristics of telecommunications outlets intended for use with balanced cabling

Electrical characteristics of the Telecommunications Outlet ^a		Requirement	Component or test standard
Interface Type	Frequency Range MHz		
Category 5 unshielded	d.c., 1 to 100	All	IEC 60603-7-2
Category 5 shielded	d.c., 1 to 100	All	IEC 60603-7-3
Category 6 unshielded	d.c., 1 to 250	All	IEC 60603-7-4
Category 6 shielded	d.c., 1 to 250	All	IEC 60603-7-5
Category 7	d.c., 1 to 600	All	IEC 60603-7-7 ^b

^a Mating and unmating under load is f.f.s.

^b In installations where other factors, such as HEM (see ISO/IEC 15018) applications take preference over backward compatibility offered with IEC 60603-7-7 (see ISO/IEC JTC 1/SC 25 N 752 Part 4), also the interface specified in IEC 61076-3-104 (see ISO/IEC JTC 1/SC 25 N 752 Part 5) may be used.

Telebox Cat.6 UTP Channel 4 connectors

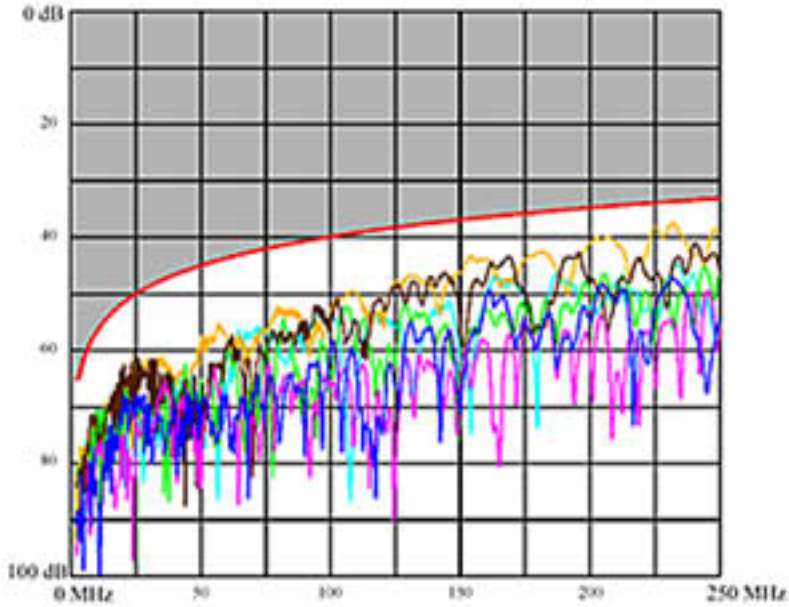
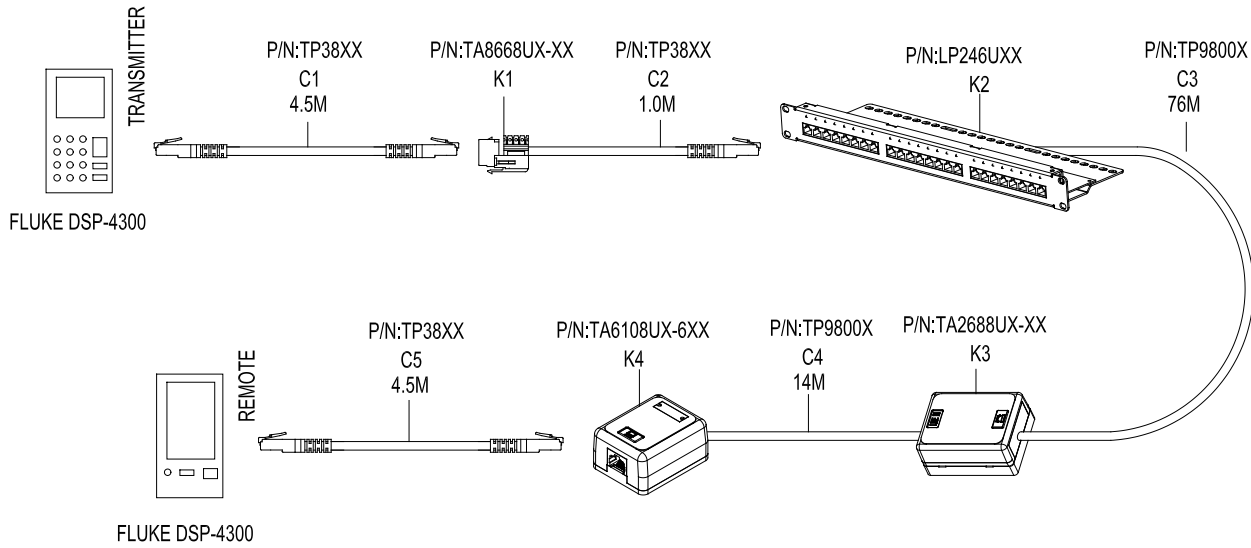

Recordings of Near End Crosstalk for all six pair combinations from 1 MHz to 250 MHz measured from wall outlet end.

Date: 2002.09.04

Blue/orange pairs: 4/5 – 1/2
 Blue/green pairs: 4/5 – 3/6
 Blue/brown pairs: 4/5 – 7/8
 Orange/green pairs: 1/2 – 3/6
 Orange/brown pairs: 1/2 – 7/8
 Green/brown pairs: 3/6 – 7/8

Limiting function: —
 Class E / Category 6 limit:

The Near End Crosstalk for all six pair combinations measured from wall outlet end complies with the specified Class E / Category 6 limit in the complete frequency range from 1 MHz to 250 MHz.

3P Project No. 102585

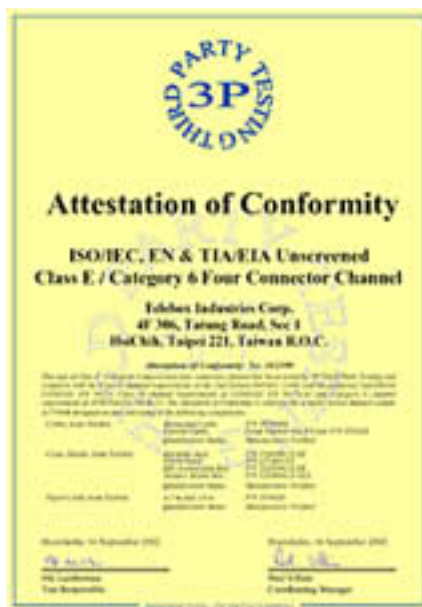

Telebox STP Channel 3 connectors system

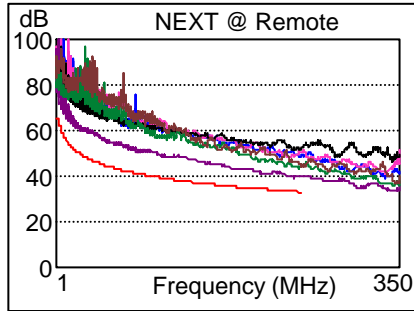
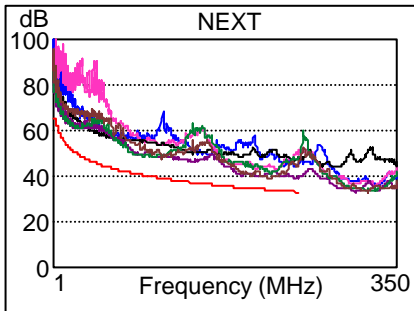
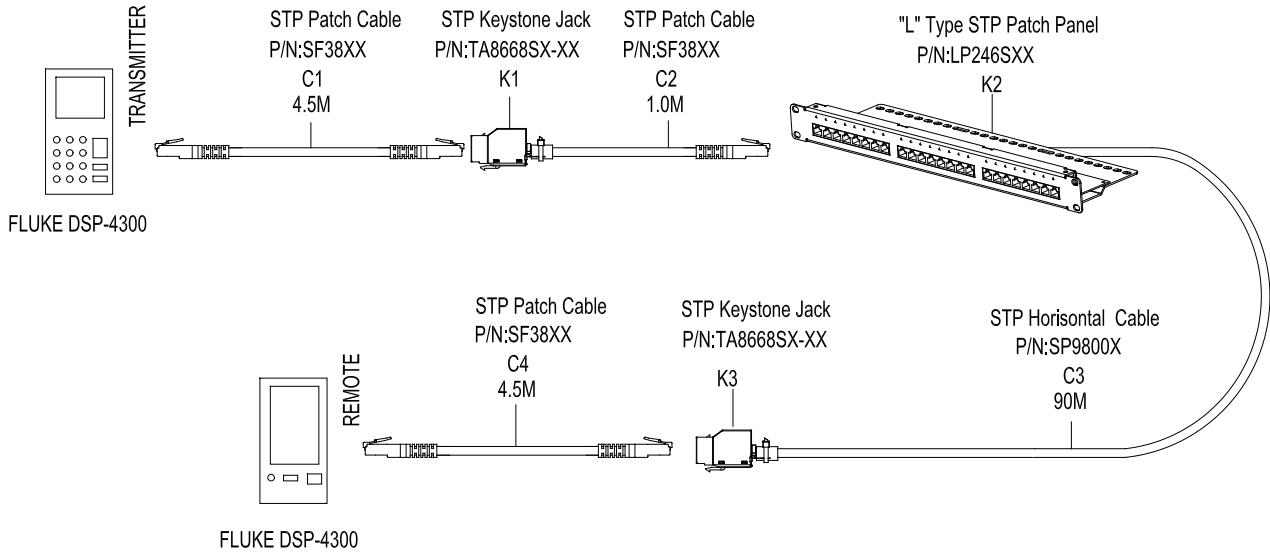

Test Summary: PASS
Cable ID: TA8668SX2+LP246S
 Headroom: 4.7 dB (NEXT 45-78)
 Site: Client Name
 Date / Time: 11/13/2002 04:54:58pm
 Test Standard: TIA Cat 6 Channel
 Cable Type: CTI+TELDOR STP 100 Ohm Cat 6
 FLUKE DSP-4300 S/N: 7885014 LIA012
 FLUKE DSP-4300SR S/N: 7885014 LIA012

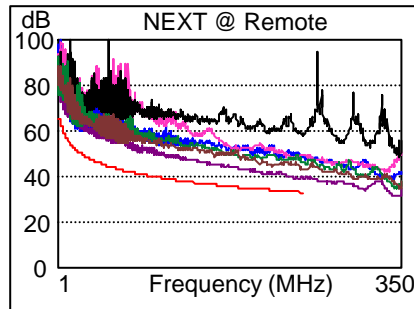
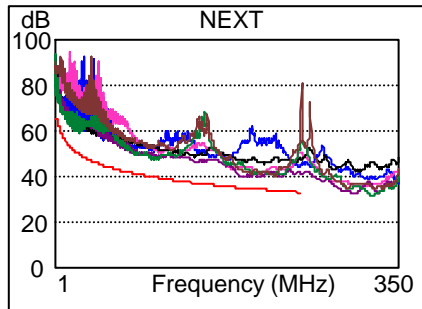

Test Summary: PASS
Cable ID: TA8668SX2+LP246S
 Headroom: 5.1 dB (NEXT 36-45)
 Site: Client Name
 Date / Time: 11/13/2002 02:35:41pm
 Test Standard: TIA Cat 6 Channel
 Cable Type: CTI STP - 100 Ohm Cat 6
 FLUKE DSP-4300 S/N: 7885014 LIA012
 FLUKE DSP-4300SR S/N: 7885014 LIA012

